



TECAPRES®

Ø95mm
7000daN

TPF 7000

VDI SAFETY



PED
2014/68/EU

MICRO

TITAN

TPH

TPS

TPSP

TPF

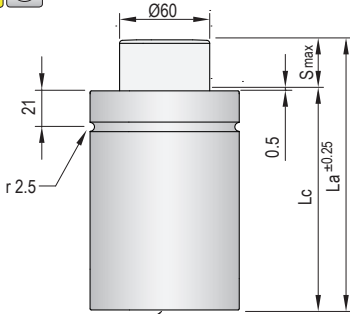

Gas charging M6
TPFV3 valve
M6-A adapter

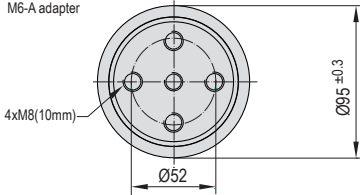

Under request

- Pressure medium **Nitrogen (N₂)**
- Max. charging pressure **140 Bar**
- Min. charging pressure **50 Bar**
- Piston seal area **50,27 cm²**
- Operating temperature **0°C - 80°C**
- Force increase by temperature **0,33 %/°C**
- Max. stem speed **25 m/min**
- Maintenance kit **Kit F7000**



Maximum strokes / minute (at 20°C)

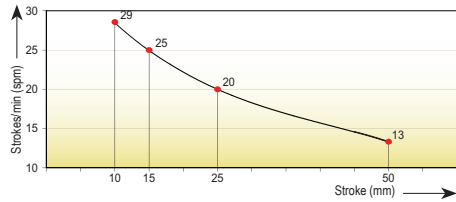

Code	Smax mm	La mm	Lc mm	Fa daN	F daN	Fc daN	P Bar	V l	Kg
TPF 7000x10	10	90	80		9310	9890		0,171	3,10
TPF 7000x15	15	105	90	7000 ±5% (20°C)	9810	10560	140	0,223	3,20
TPF 7000x25	25	135	110		10195	11090	(20°C)	0,340	3,45
TPF 7000x50	50	210	160		10640	11720		0,622	4,95

Force/stroke ratio

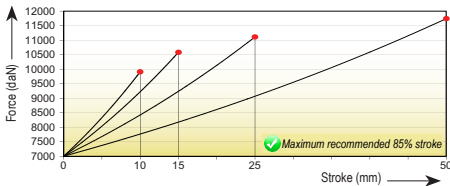

Initial force/charging pressure ratio

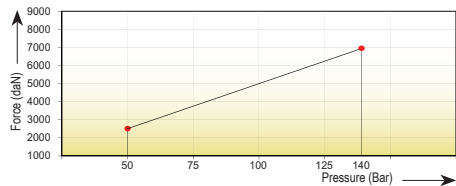

Assembly possibilities



Follow guidelines
Page 287



DROP-IN



SCREWS

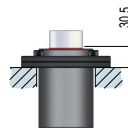

FS 95-FSC 95



FI 95-FI 95/1